

SE-9-350-700-G1T

T-PWM™
Dimming technology

Flicker-free
IEEE 1789

Dimmable:
0.01-100%



Dati tecnici / Technical data

Input voltage Vac	Output power range W	Output voltage Vdc	Output current mA	Dimension mm (LxWxH)
220-240 (50/60)Hz	0.7~8.4	2-12	350-700	111x35x20

Disegno tecnico / Technical drawing

Cavo di ingresso
Input wire
0.75~1.5mm²
4.5~5 mm

Cavo di uscita
Output wire
0.5~1.5mm²
4.5~5 mm

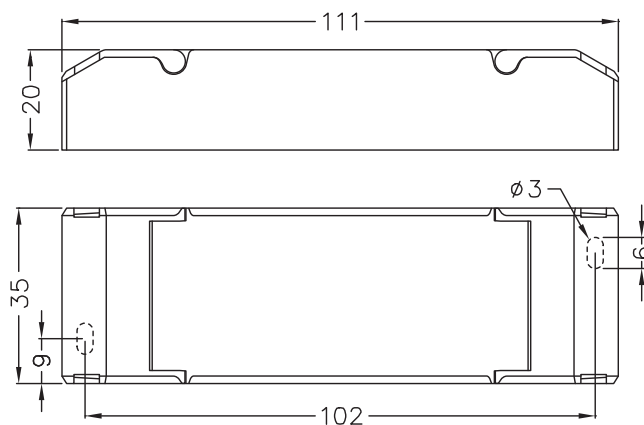

**Selezione corrente di uscita tramite DIP switch
Output current selection via DIP switch**

SE-9-350-700-G1T	DIP Switch	<input type="checkbox"/> 1 <input type="checkbox"/> 2 <input type="checkbox"/> 3	<input type="checkbox"/> 1 <input type="checkbox"/> 2 <input type="checkbox"/> 3	<input type="checkbox"/> 1 <input type="checkbox"/> 2 <input type="checkbox"/> 3	<input type="checkbox"/> 1 <input type="checkbox"/> 2 <input type="checkbox"/> 3	<input type="checkbox"/> 1 <input type="checkbox"/> 2 <input type="checkbox"/> 3	<input type="checkbox"/> 1 <input type="checkbox"/> 2 <input type="checkbox"/> 3	<input type="checkbox"/> 1 <input type="checkbox"/> 2 <input type="checkbox"/> 3	<input type="checkbox"/> 1 <input type="checkbox"/> 2 <input type="checkbox"/> 3	ON OFF
	Output Current	350mA	400mA	450mA	500mA	550mA	600mA	650mA	700mA	
	Output Voltage	2-12V	2-12V	2-12V	2-12V	2-12V	2-12V	2-12V	2-12V	
Output Power	0.7-4.2W	0.8-4.8W	0.9-5.4W	1-6W	1.1-6.6W	1.2-7.2W	1.3-7.8W	1.4-8.4W		

Scegliere il valore di corrente quando il driver è spento
Please choose the current value when the driver is power off

LED driver in corrente costante - Constant current LED drivers

Output	Output Voltage	2-12Vdc		
	Max Output Voltage	≤22V		
	Output Current	350-700mA		
	Load Power Range	0.7W-8.4W		
	Strobe Level	No visible flicker/High frequency exemption level		
	Dimming Range	0~100%, down to 0.01%		
	LF Current Ripple(<120Hz)	<3%		
	Current Accuracy	±5%		
	Ripple & Noise	≤2V		
PWM Frequency	3600Hz			
Input	Dimming Interface	Triac leading edge/ELV trailing edge		
	Input Voltage Range	220-240Vac		
	Frequency	50/60Hz		
	Input Current	≤0.08A/230Vac		
	Power Factor	PF>0.9/230Vac (Foll load)		
	THD	THD<15%/230Vac (Foll load)		
	Efficiency	>70%@700mA		
	Inrush Current (typ.)	Cold start10A@230Vac (Test twidth=200 us tested under50% Ipeak)		
	Anti Surge	L-N: 1kV		
Leakage Current	<0.5mA/230Vac			
Environment	Working Temperature	ta: -20 ~ 45°C tc: 90°C		
	Working Humidity	20 ~ 95%RH, non-condensing		
	Storage Temperature, Humidity	-40 ~ 80°C, 10 ~ 95%RH		
	Temperature Coefficient	±0.03%/°C (-20°C ~ 45°C)		
	Vibration	10-500HZ, 2G 12min/1cycle, 72 min for X, Y and Z axes respectively.		
Protection	Overload Protection	Shut down the output and recover automatically once it exceeds 1.02-1.35 times of the rated power.		
	Overheat Protection	Intelligently adjust or turn off the current output if the PCB temperature ≥110°C. When the PCB temperature <90°C, automatically recover normal output.		
	Short Circuit Protection	When short circuit occurs, shut down the output and recover automatically.		
Safety & EMC	Withstand Voltage	I/P-O/P:3750Vac		
	Insulation Resistance	I/P-O/P:500Vdc/25°C/70%RH≥100MΩ		
	Safety Standards	CCC	China	GB19510.1, GB19510.14
		TUV	Germany	EN61347-1, EN61347-2-13, EN62493
		CE	European Union	EN61347-1, EN61347-2-13, EN62384
		KC	Korea	KC61347-1, KC61347-2-13
		RCM	Australia	AS61347-1, AS61347-2-13
		ENEC	Europe	EN61347-1, EN61347-2-13, EN62384
		CB	CB member states	IEC61347-1, IEC61347-2-13
	EMC Emission	EAC	Russia	IEC61347-1, IEC61347-2-13
		CCC	China	GB/T17743, GB17625.1
		CE	European Union	EN55015, EN61000-3-2, EN61000-3-3, EN61547
		KC	Korea	KN15, KN61547
		RCM	Australia	EN55015, EN61000-3-2, EN61000-3-3, EN61547
	EMC Immunity	EN61000-4-2,3,4,5,6,8,11, EN61547		
Strobe Test Standard	IEEE 1789			
Others	Dimensions	111×35×20mm(L×W×H)		
	Packing	122×36×22mm(L×W×H)		
	Weight(G.W.)	77.5g±10g		

Schema di applicazione custodia protettiva
Protective Housing Application Diagram



Utilizzare uno strumento per sollevare la custodia protettiva sul pannello laterale
Use a tool to pry up the protective housing on the side panel



Sollevare la custodia di protezione nella posizione della piastra laterale con un utensile
Pry up the protective housing in the side plate position with a tool

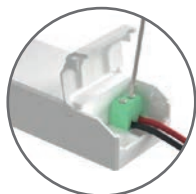

Collegare i cavi elettrici con un cacciavite come mostra lo schema elettrico
Connect to electrical wires with a screwdriver as wiring diagram shows



Premere la piastra di tensione per fissare i fili elettrici
Press down the tension plate to fix the the electrical wires



Chiudere la custodia protettiva
Close the protective housing